

ENGINES

ENGINE OIL FILTRATION

Fitting a By-pass filter system to an engine offers:

- Particle removal to 1 Micron plus 100% water removal.
- Fitting a Filtakleen filter to an engine will extend the oil and filter life up to 160,000kms /96,000 possible between changes.

Removing all water content reduces the acid formation in the oil. This takes away the workload of the alkaline additives, and extends the life of the TBN, and the working life of the oil. It also reduces the workload of the main filter, extending its life.

The engine will run with cleaner oil, which means a cleaner engine, less component wear and reduced emissions.

When a Filtakleen system is fitted, the oil and main filter should be changed. Afterwards Filtakleen filters should be changed 3 monthly, with the main filter and oil being changed annually or when the indicated mileage is reached. The engine oil filtration system comes in 4 different sizes;

FIVE PROVEN FACTS

- When oil in an internal combustion engine is kept clean it does not wear out, its viscosity does not change; its additive package is not depleted; acids are kept at minimal levels in the engine and clean oil does not have to be changed.
- When an engine is run on clean oil 100% of the time, engine wear is significantly reduced and you can routinely expect to more than double the historical or expected life of the engine.
- Clean oil circulating in an engine 100% of the time does not have to be routinely changed. The only time an oil change will be necessary is when the oil becomes contaminated with excessive fuel water or coolant.
- Through the use of the Filtakleen program savings can be realized of 75%-80% of both usage and waste disposal costs of oils, fluids, coolants, solvents, and factory full flow filters.
- Clean oil circulating in an engine 100% of the time not only meets but far exceeds engine manufacturers warranty requirements.

Part Numbers

Product	Part No	Description	System Size
Engine Kits	FF368	Bantam duty filter kit (white)	8 litre sump
	FF668	Light duty filter kit (red)	14 litre sump
	FF878	Heavy duty filter kit (blue)	36 litre sump
	FF988	Maxi duty filter kit (blue)	72 litre sump
Hydraulic Oil Kits	FFHY778	Heavy duty filter kit	900 litre tank
	FFMY788	Maxi duty filter kit	2000 litre tank
	MX200	Mobile cleaning station	
Filter Cartridges	C58	Bantam duty replacement filter	
	C68	Light duty replacement filter	
	HYC78	Heavy duty replacement filter (engines & Hydraulics)	
	MYC88	Maxi duty replacement filter (engines & Hydraulics & MX200)	

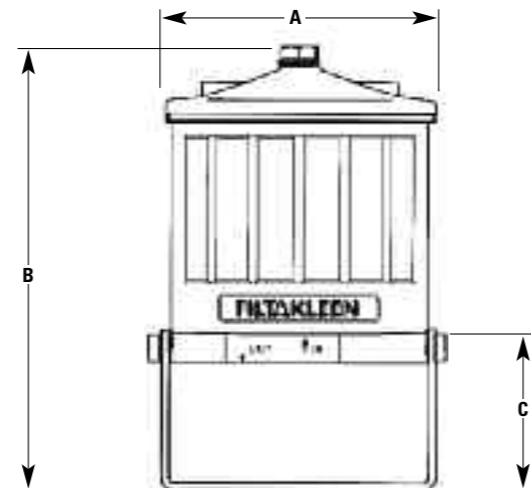

Dimensions (mm)

	Bantam	Light	Heavy	Maxi
A	115	115	166	213
B	200	240	275	297
C	88	88	105	127

above sizes are approximate



By-Pass Filtration Systems For Hydraulic Systems and Engines



Filtakleen - maximizing industrial performance world wide...

www.interlubesystems.com
HELP DESK · PRODUCT RANGE · LITERATURE REQUEST

For advice on which product is most suitable for your needs - visit our web site from where you can e-mail us your requirements. Our Help Desk will respond within 24hrs by return e-mail or phone.

The Filtakleen Oil Purification System Offers

Continuous Preventative Maintenance & Significant Cost Savings

- FINE PARTICLE REMOVAL DOWN TO 1 MICRON
- 100% WATER REMOVAL FROM OIL

MAJOR LONG TERM BENEFITS

- **Save Money** - Greatly increase the life of your oil+filters
- **Save Time** - Change only the Filtakleen element
- **Reduce Waste** - Less used oil or filters needing disposal

Running your system with cleaner oil will:

- **Prevents System Wear** - Removes Sandpaper effect of fine particles and corrosion caused by presence of water
- **Enhance Performance** - prevents fine tolerance valves from sticking
- **Improved Reliability** - less component wear reduces risk of system failure

System Features

Hydraulic oil even when new will have a certain level of particle contamination, and is typically graded at ISO 17/15/14. When oil is added to a system further contamination can occur. Whilst under operating conditions air and moisture, as well as particles from seals and hoses, can add to the contamination and degradation of the oil. Fitting a Filtakleen filter will not only reverse this process but it will clean your oil so thoroughly it will be cleaner than when it was new!



ULTRA FINE DEBRIS REMOVAL - 1 MICRON

Once installed Filtakleen's filtering efficiency removes all damaging wear particles normally missed by the main filter, this removal of the ultra fine debris at source immediately reduces the risk of malfunctioning control valves as well as dramatically reducing the erosion of the hoses and seals caused by these fine particles. In addition Filtakleen takes away the risk of silting of the suction filters which can cause pump damage through cavitation. Standard machine filters will only offer filtration of particles of between

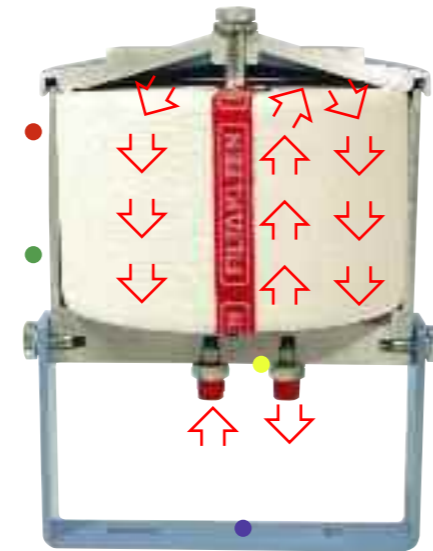

The high tech cartridge gives continuous all round protection against water and ultra-fine debris with contaminated oil entering the filtakleen unit at the base flowing up the centre tube through the 1 micron filter before flowing back to the hydraulic circuit. Flow rates through filter 4.1 l/min to 6.1 l/min depending on unit fitted.

Design Features

- Special casing for easy element replacement
- Powder coated 1-piece aluminium body for total durability
- Machined sealing edges for 100% filtering efficiency
- Universal mounting bracket

100% WATER REMOVAL - STOP ACIDITY

By its ability to remove all water content Filtakleen reduces dramatically the normal acid build-up in the oil so avoiding the corrosion and chemical degradation of all the seals and hoses as well as preventing unnecessary pump wear and cavitation through invert emulsions.

10 –25 microns. Much of today's machinery work with tolerances of as fine as 4—5 microns. Therefore removal of particles of this size is critical to system performance. The unique design of the Filtakleen filter means that removal of particles down to 1 Micron is achieved. Additives are not removed as these are sub micron size. By fitting Filtakleen, you are creating Major Long term benefits in both component life and circuit operation.

How it works

The filter is installed in the circuit after the pump. It is connected into the system by hoses and mounted remotely at a convenient location. The filter works by taking a percentage of the oil and slowly percolating it through a dense filter medium. The flow rate of 4-6l/min will not affect system performance as it is taking only a percentage (typically 10-12%) of the total flow. This low flow rate means that filtration to a much finer tolerance than that achieved from in-line filters is possible.

Manifold

A Manifold is fitted to their bottom of the filter. This acts as a pressure reducer with a relief valve and maintains a consistent flow so as to ensure optimum filter efficiency.

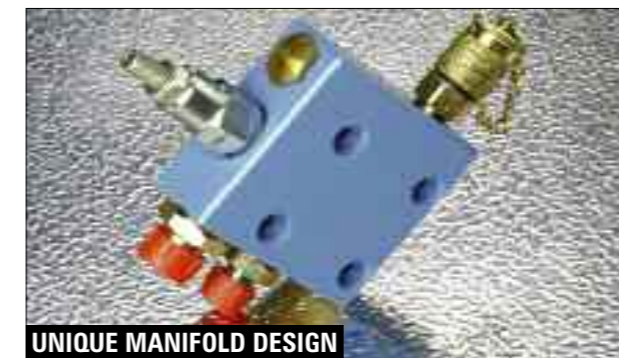

UNIQUE MANIFOLD DESIGN

Test results showing the improvement in oil cleanliness achieved, resulting in oil cleaner than new

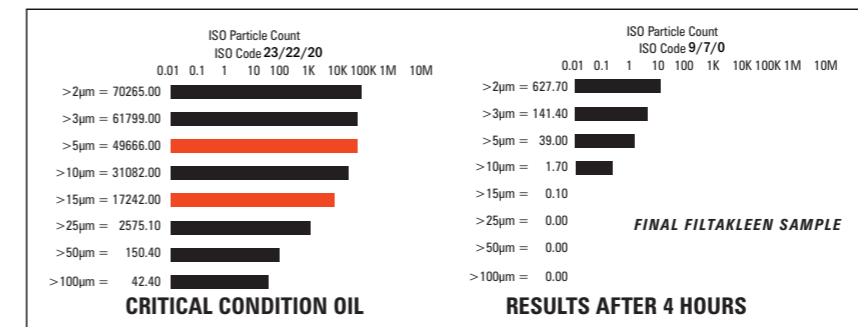

Results shown are subject to variations according to system size, flow rate, and original oil condition

This illustration shows the improvement in oil achieved by removing water content



original emulsified oil after 1 month / 2 cartridge changes after 2 months / 4 cartridge changes

Maintenance

Changing the element is a quick and easy job. Incorporating a ball valve into the inlet side of the circuit, means the filter can be isolated. The retaining bolt is unscrewed the lid taken off, the old filter removed and replaced with the new one. A simple no-mess job that takes a couple of minutes

Recommended filter change frequency is 500 hours or quarterly. For filters installed on a system with used oil initial changes should be more frequent. (Contact Interlube for further information)

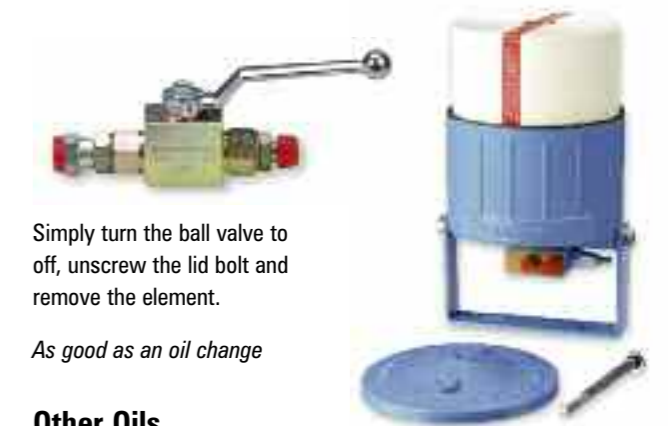

As good as an oil change

Other Oils

The Filtakleen filtration is suitable for use with a wide range of oils such as gear oils plus other mediums such as dielectric fluid and bio diesel.

All filters come with a range of fittings for installation: Interlube offer a supply and fit service for all their filter products. However for customers who wish to install themselves, each filter comes with a range of fittings.

MX200 Mobile Cleaning Station

Mobile low pressure filter system used to remove particles and water contamination from hydraulic systems with the ability to move from one machine to another. Can also transfer, without filtration, of large & small quantities of used oil from hydraulic system reservoirs to storage for disposal.

Can be used for

- Periodic clean ups
- Flushing
- Pre-filtering new oil
- Filling tanks and machines

